

LAMTRAC

SPECIFICATIONS	14" Triple Grouser Pads	18" Single Grouser
Track Width	14 in / 355 mm	18 in / 457 mm
Overall Length (no attachment)	153 in / 3886 mm	153 in / 3886 mm
Overall Height	98 in / 2490 mm	100 in / 2540 mm
Overall Width	74 in / 1880 mm	78 in / 1981 mm
Ground Clearance	15 in / 381 mm	16 in / 406 mm
Weight (no attachment)	16,060 lbs / 7,285 kg	16,200 lbs / 7,348 kg
Ground Pressure	6.88 psi	5.4 psi

ENGINE	
Brand/Model/Emissions	Cummins/B4.5/Stage V
Displacement	275 in ³ / 4.5L
Power (@2000 rpm)	155 hp / 115 kw
Torque (@1200 rpm)	525 ft-lb / 712 Nm
DEF Tank Capacity	5 Gal / 18.92L
Engine Compartment lights	1
Fuel Tank Capacity	42.46 Gal / 160.76 L

Hydraulics	
Attachment pump size	4.76 in ³ / 78cc
Attachment pump max pressure	6000 PSI / 413.8 BAR
Attachment pump flow	0-44 GPM / 0-166.5 L/Min
Description of variable flow capacity	Controlled Electronically
Tank capacity (at full mark)	23.6 Gal/89.3L
Coupler count/size/ratings/style (oringbus)	O-ring Face
Auxiliary pump size	2.69 in ³ / 44 cc
Auxiliary pump flow	25.6 GPM / 96.8L
Hydraulic Compartment lights	1

CAB	
Cab certification	ROPS ISO 8082 / FOPS ISO 8083 / OPS ISO 8084
Display details	4.3 in / 110 mm Color
Joystick Sensitivity options	Yes
Pneumatic seat w/Arm adjust	Yes
Electrical outlets	1
USB	2
Cup holder	Yes
Radio	AM/FM/Bluetooth
Exterior light Front	LED Light Bar 14,000 lumens
Exterior light Side	2x850 Lumens
Interior light	Yes
Rear View Camera	7in HD Color Wireless
Cab filtration	Mechanical 50Pa Merv 16 HEPA

Electrical	
Voltage	12 VDC
Total battery cranking amp capacity	1500 CCA
Alternator	160A
Wiring	Moduled and seamless
Trouble shooting capability details	Can Bus Provided
Front Attachment Power	8 Pin

Undercarriage	
Lubricated Steel Track Equivalent	

Options	
Rear Bumper	
Hydraulic Winch	15,000 lbs / 6,000 kg



LTR 6160 RST

Dedicated mulching equipment performance in a versatile compact package.



1.888.LAMTRAC

© The following are trademarks of Lam trac Global Inc.
© 2026 LAMTRAC Global Inc. All rights reserved.

LAMTRAC.COM

LTR 6160 RST is Lamtrac's fourth generation in its popular CTL style mulcher carrier. This model features the same industry exclusive features as its predecessors and adds many updates and improvements that clearly make this product the leader in its category. Its steel track platform is designed for the rigidity and rigours of extreme duty forestry applications.



6160 RST

CAB

Easily identified as the most spacious, comfortable, and safe operator quarters in this product category, the side entry provides easy access to the cab. LTR 6160 RST has a pneumatic suspension seat, high definition rear view camera and ergonomic joysticks for smooth and comfortable equipment control. This ROPS/FOPS/OPS certified cab offers superb peripheral visibility and has the unique feature of being mechanically pressurized to eliminate dust infiltration.



UNDERCARRIAGE

LTR 6160 RST has a purpose built chassis that maximizes stability and traction. This track system design ensures long life and optimizes uptime in harsh forestry conditions.



ENGINE

The heartbeat of LTR 6160 RST is Cummins latest B4.5, 155HP Stage V diesel engine technology. This engine is not only smaller and lighter, but offers 16% more power, 11% more torque in an EGR free engine than the prior Tier IV alternative. This engine requires no crankcase filter maintenance, offers advanced fuel economy and reduces sound.



COOLING

Superior cooling capacity is integrated into the LTR6160 RST, The 3-tiered radiator controls air, engine, and hydraulic temperatures to ensure uninterrupted operations in ambient temperatures up to 125F (52C) and prolongs the life of all components and fluids.

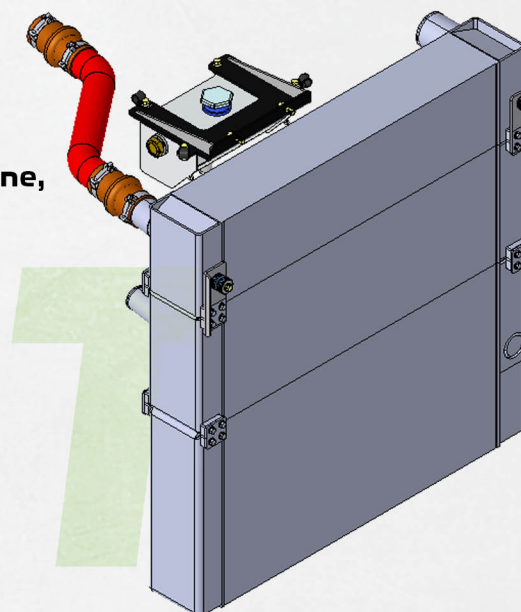

HYDRAULICS

Lamtrac's key to success since the launch of the 6000 series tractors has been in the hydraulic system design. Hydraulic components utilized in a closed loop configuration delivers the undisputed highest hydraulic performance in the industry. Professionals know that hydraulic performance is the key to productivity and profitability.

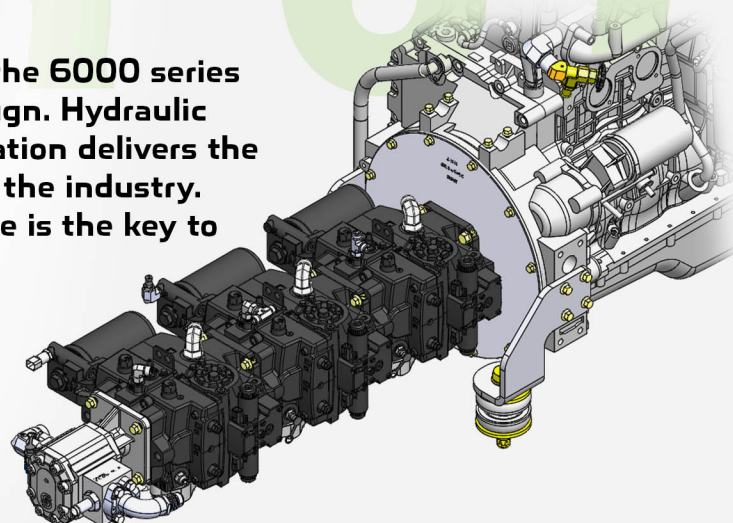

QUICK ATTACH PLATE

While the LTR 6160RST is primarily designed to provide the highest hydraulic performance for land management applications, this robust new design allows this prime mover to be host to a wide variety of common attachments to bring versatility and many revenue streams to their owners.

